

DE-BUG magnetic diesel filter is the Patented and proven cure of diesel bug, including microbial contamination. DE-BUG is a one time fit and forget solution and once installed in the fuel line, the DE-BUG treatment unit cleans and polishes your diesel fuel as your appliance is operating.

DeBug L140

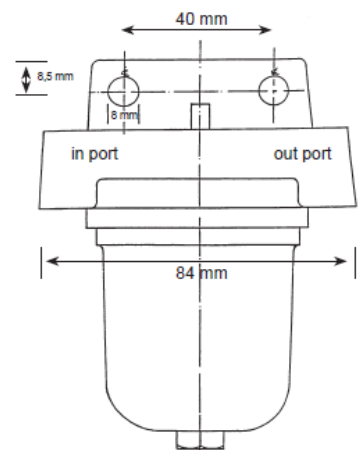

FUEL TYPES	Diesel fuel, marine diesel, light oils and gas oil
RECOMMENDED FLOW RATE	Up to 140 litres/hour.
FLOW DIRECTION WITH UNIT MOUNTED	Left to right
MATERIALS	Marine grade LM6 anti-corrosive aluminium alloy.
WEIGHT	0.31 Kilograms
SIZE	60 mm diameter by 105 mm height by 84mm wide
PORT SIZE	¼ inch NPT
OPERATING PRESSURE	40 psi
INSTALLATION	Two 8mm bolts.

